



Product Evaluation Report

PER-08035

This Document Published By:

Progressive Engineering Inc.

Initial Listing
February, 2009

Re-Approved
December 14, 2010

58640 State Road 15 574-533-0337
Goshen, Indiana 46528 www.p-e-i.com

Listed Products

- Style 2B 8' Railing System
- Style 2B 10' Railing System
- Style 2C 8' Railing System
- Style 2D 8' Railing System

Listed For

Royal Outdoor Products
P.O. Box 360
Milford, IN 46542

Approved Manufacturer

Royal Outdoor Products
401 S. Syracuse Street
Milford, IN 46542

Progressive Engineering Inc. is an accredited Testing Laboratory and Third Party Quality Control Agency. This **Product Evaluation Report** represents a product that Pei has a follow-up service agreement with. This **Product Evaluation Report** in no way implies warranty for this product or relieves **Royal Outdoor Products** of their liabilities for this product. Pei is accredited to ISO Standard 17020 and 17025. This **PER** is an official document if it is within one year of the initial or renewal date.

Listing Details

Styles 2B8, 2B10, 2C8 and 2D8 Railings are used for exterior guards for balconies, porches, stairs and decks. The top and bottom railings are manufactured with openings spaced under 4" to accommodate the vertical balusters.

Styles 2B8, 2B10, 2C8 and 2D8 Railings have been tested and evaluated for structural strength to meet design loads and requirements of the codes listed under Code Compliance of this PER.

Product Descriptions

Style 2B10 railing is manufactured from coextruded PVC plastic, with a UV inhibitor to prevent sun damage or color change along with impact modifiers to provide stability. The Style 2B10 Railing System is designed for an installed height of 42" with a maximum length of 120" when measured from center-of-post to center-of-post. Each post is a PVC sleeve placed over a 4x4 timber. Style 2B10 has a span rating of 116". The top rail sections are reinforced with a .101" thick steel reinforcement. Two (2) crush blocks are utilized to reinforce the bottom rail section.

Styles 2B8, 2C8 and 2D8 are also manufactured from coextruded PVC Plastic with a UV inhibitor to prevent sun damage or color change along with impact modifiers to provide stability. The Styles 2B8, 2C8 and 2D8 are designed for an installed height of 36" or 42" with a maximum length of 96" when measured from center-of-post to center-of-post. Style 2B8 post is a sleeve over a 4x4 timber. Styles 2C8 and 2D8 have a span rating of 92" with the use of a .136" thick x 4" x 4" PVC post. Styles 2C8 and 2D8 both have galvanized steel post mounts. The galvanized steel post mount components are nominally 4" x 4" and are bolted to the deck structure through the pre-drilled holes. The steel post mount must extend a minimum of 20-1/4" above the deck surface. The top rails for Styles 2B8, 2C8 and 2D8 are reinforced with a .114" thick aluminum rail reinforcement. Styles 2B8 and 2D8 use one crush block to reinforce the bottom rail sections. Style 2C8 has a .114" thick aluminum rail reinforcement in the bottom rail with no crush block.

General Product Usage 2B8, 2B10, 2C8 & 2D8

1. Styles 2B8, 2B10, 2C8 & 2D8 Railings shall be installed in accordance with Royal Outdoor's Product Instructions and subject to the conditions of this PER. A copy of Royal Outdoor's Product Installation Instructions shall be made easily available to the installer.
2. All framing, wood posts, beams, joists, stringers and associated connections needed to support the 2B8, 2B10, 2C8 & 2D8 Railings and Post Mount System is outside of the scope of this PER. All framing shall follow applicable codes or be designed by a licensed Engineer. Stairways shall be designed and constructed in accordance with the applicable codes.
3. Style 2B8 Railing is to be installed and fastened to wood framing using four (4) #12 by 2-1/2 inch long stainless steel wood screws. One (1) #12 x 1-1/2" long self-drilling screw is driven through the inner face of the bracket and one (1) screw is driven through the outer face of the bracket of the top rail. These screws are driven through the guardrail and the reinforcement. No screws are driven through the bracket on the bottom rail. One 2" high crush block is fastened to the bottom rail at the center of its length. Only the fasteners and fastener configurations specified for use have been evaluated for installation of the Style 2B8 Railing System.
4. Style 2C8 and 2D8 Railings are to be installed to framing with (2) steel post mounts. The steel post mounts are bolted to the deck section using 5/16" x 2-1/4" long carriage bolts. The routed post sleeves are then slid over the steel post mounts. One (1) #12 x 1-1/2" stainless steel screw is inserted in the hole found in the post plate and into the guardrail. The screw does not contact the reinforcement. For Style 2C8 one 2" high crush block is fastened to the bottom rail at the center of its length. For Style 2D8 the top and bottom rail have an aluminum reinforcement and no crush block. Only the fasteners and fastener configurations specified for use have been evaluated for installation of Styles 1C8 & 1D8 Railing Systems.

General Product Usage 2B8, 2B10, 2C8 & 2D8

5. Style 2B10 Railing is to be installed and fastened to wood framing using four (4) #12 by 2-1/2 inch long stainless steel wood screws. Two (2) #12 x 1-1/2" long self-drilling screws are driven through the inner face of the bracket and one (1) screw is driven through the outer face of the bracket of the top rail. These screws are driven through the guardrail and the steel reinforcement. The bottom rail does not get fastened to the brackets. Two (2) 2" high crush blocks are fastened to the bottom rail to provide three (3) equidistant spaces between the posts. Only the fasteners and fastener configurations specified for use have been evaluated for installation of the Style 2B10 Railing Systems.

Test Documentation

- Test Report FH-1448 - Per ASTM E84 Surface Burning Characteristics - Dated 2/13/2004
- End Use Adjustment Factor Using PEI Test Report No.'s 2003-565 (D), 2003-565 (E) and 2003-565 (F)
- PEI Test Report No. 2007-0755 - ASTM D638 Tensile Test on Xenon Arc Exposed Plastic- Dated 6/30/2007
- PEI Test Report No. 2008-0837 (D) - ASTM D7032 Guardrail Test on Style 1B8 Railing System with a .114" Thick Aluminum Rail Reinforcement - Dated 7/22/2008
- PEI Test Report No. 2008-0837 (E) - ASTM D7032 Guardrail Test on Style 1C8 Railing System with a .114" Thick Aluminum Rail Reinforcement - Dated 9/04/2008
- PEI Test Report No. 2008-0837 (F) - ASTM D7032 Guardrail Test on Style 1D8 Railing System with a .114" Thick Aluminum Rail Reinforcement - Dated 9/12/2008
- PEI Test Report No. 2008-0837 (G) - ASTM D7032 Guardrail Test on Style 1B10 Railing System with a .101" Thick Steel Rail Reinforcement - Dated 6/12/2008
- PEI Test Report No. 2008-0837 (H) - ASTM D7032 Guardrail Post Mount Tests - Dated 9/15/2008
- PEI Test Report No. 2008-0837 (I) - Guardrail Corner Connection Test - Dated 10/09/2008

Tested to

- ASTM E84-03 - Standard Test Method for Surface Burning Characteristics of Building Materials**
- ASTM D638-03 - Standard Test Method for Tensile Properties of Plastic**
- ASTM D7032-04 - Standard Specification for Establishing Performance Ratings for Wood Plastic Composite Deck Boards and Guardrail Systems (Guards for Handrails)**
- ASTM G155-04 - Standard Practice for Operating Xenon Arc Light Apparatus for Exposure of Non-Metallic Materials.**
- ASTM E8 - Standard Test Methods for Tension Testing of Metallic Materials**

Quality Assurance Documentation

- Deck and Railing Instructions by Royal Outdoor Products
- A Quality Control Manual for Railing Manufacturing - Dated 1/4/2010
- A follow-up Listing & Inspection agreement between Pei and Royal Outdoor Products
- A MSDS sheet for PVC Compounds dated 2/10/2005
- A Steel Reinforcement Material Certification dated 7/30/2007

Code Compliance for 2B8 & 2B10 Railing Systems

2003 International Residential Code Section R312.1	2006 International Residential Code Section R312.1
2003 International Building Code Section 1607.7.1	2006 International Building Code Section 1607.7.1

Code Compliance for 2C8 & 2D8 Railing Systems

2003 International Residential Code Section R312.1	2006 International Residential Code Section R312.1
--	--

Product Labeling

Styles 2B8, 2B10, 2C8 & 2D8 Railing Systems must be labeled with at least the following information:

1. The Styles 2B8, 2B10, 2C8 and 2D8 Railing names
2. Manufacturing Date Code
3. Manufacturer's name, Logo or website
4. This PER number & Pei's name or Logo

2B8 Railing System

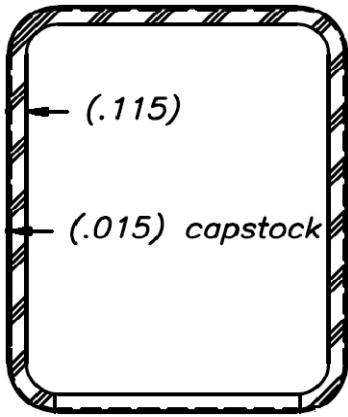
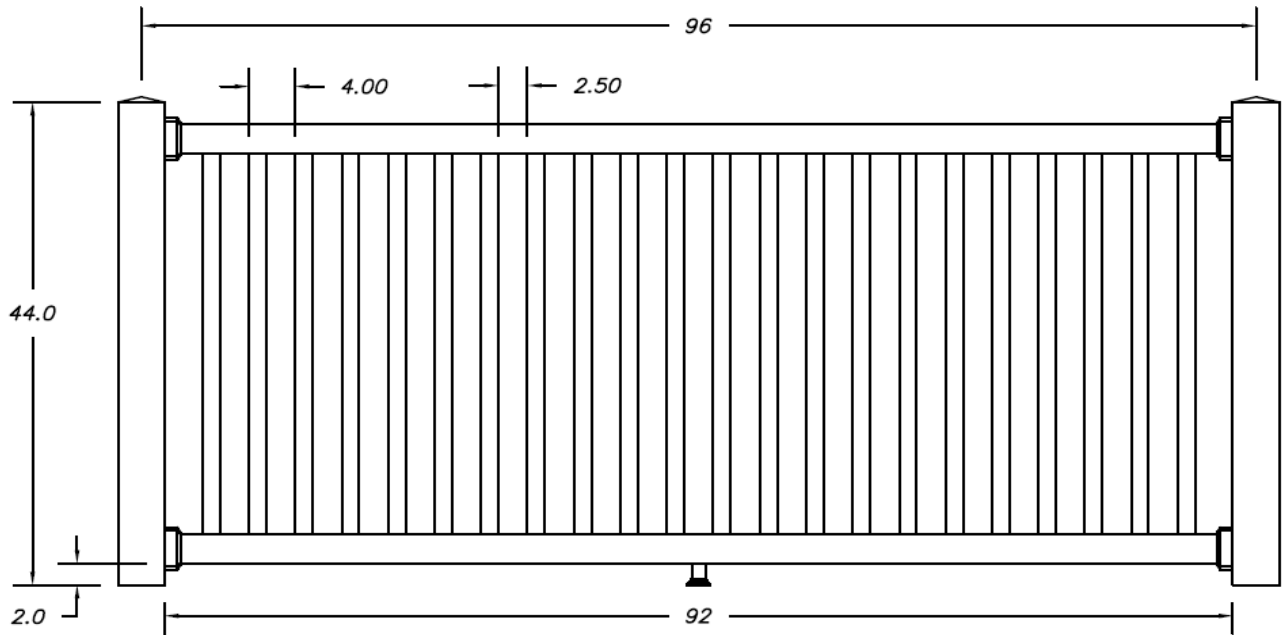

2.10" x 2.661" Rail

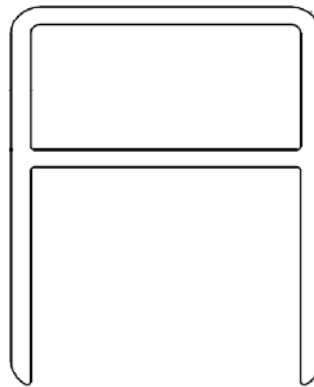

Aluminum Reinforcement

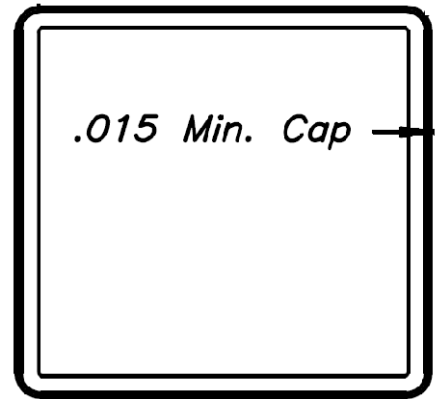

1.5 x 1.5 Picket



4" Square Post

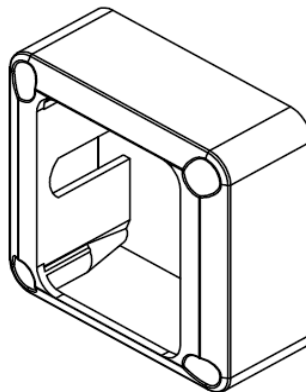

Wall Mount

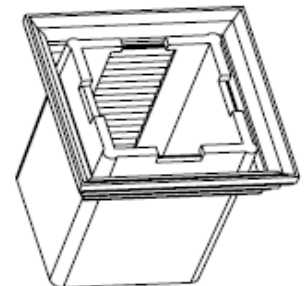

Crush Block

2C8 Railing System

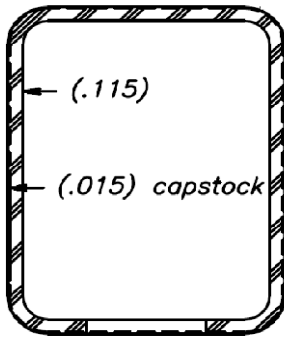
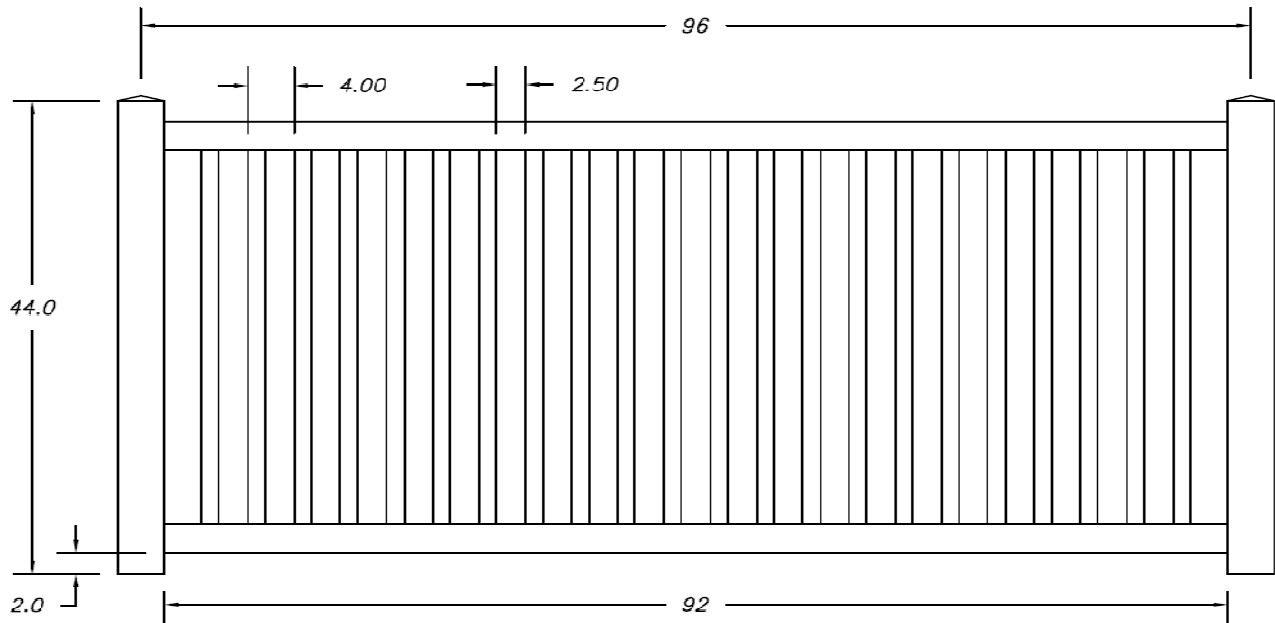

2.10" x 2.661" Rail

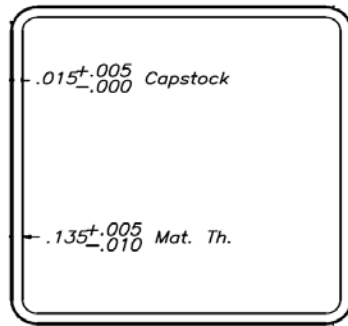

4" Routed Square Post

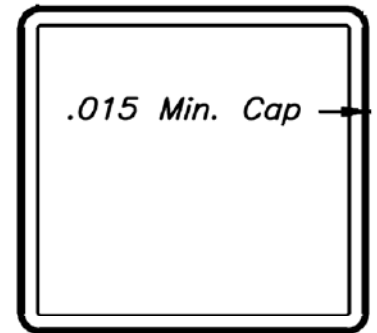

1.50" X 1.50" Picket

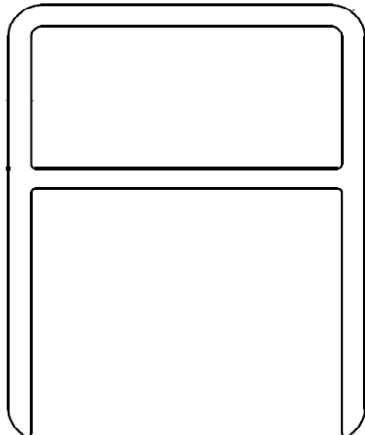

Aluminum Reinforcement
(Top & Bottom Rail)

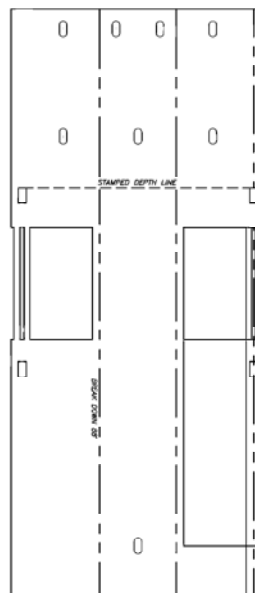

4" Post Mount

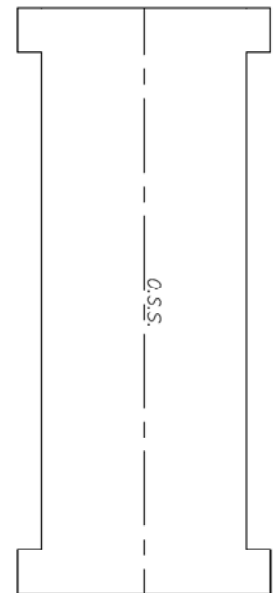

4" Post Mount Plate

2D8 Railing System

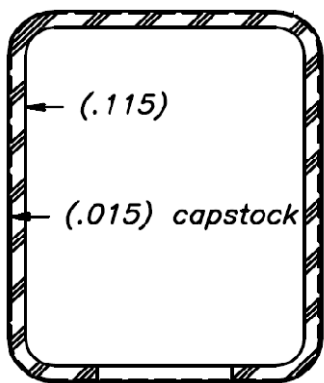
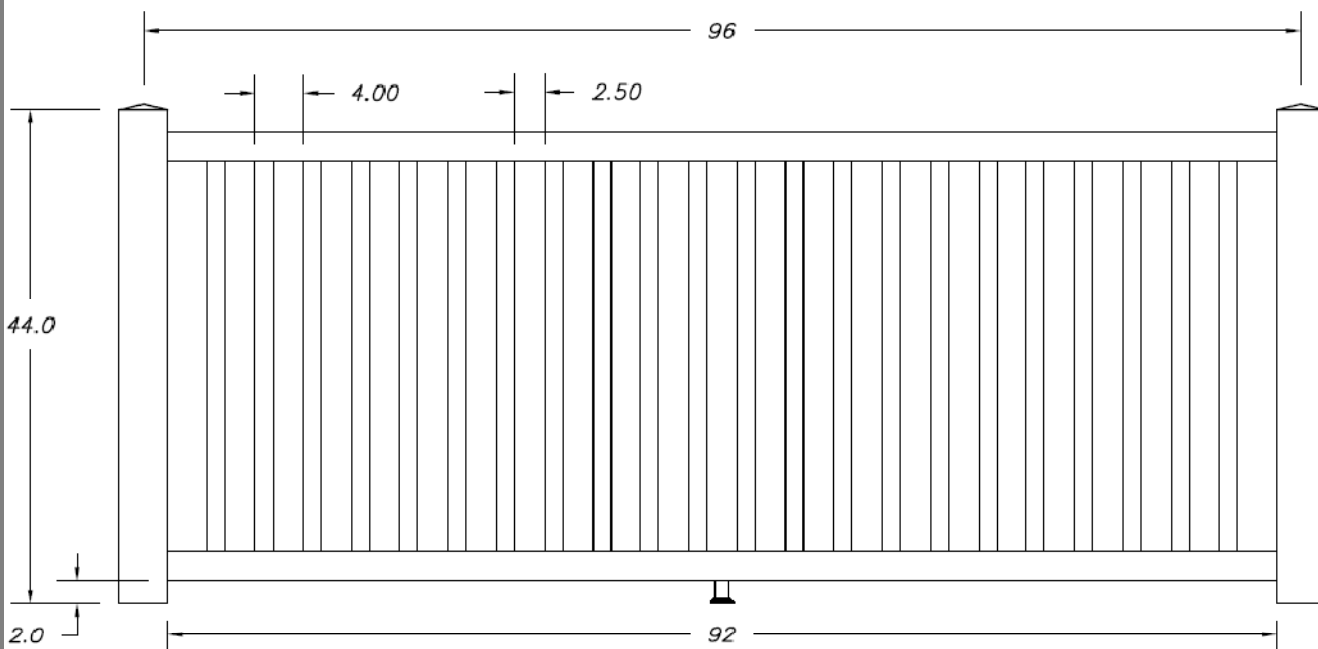

2.10" x 2.661" Rail

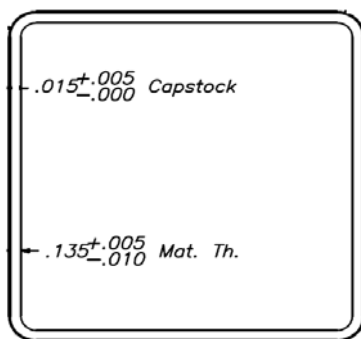

4" Rounded Square Post

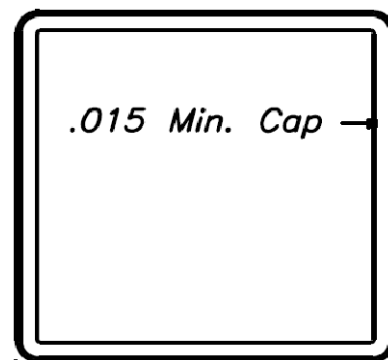

1.50" x 1.50" Picket

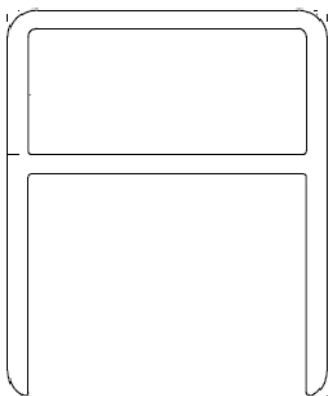

Aluminum Reinforcement

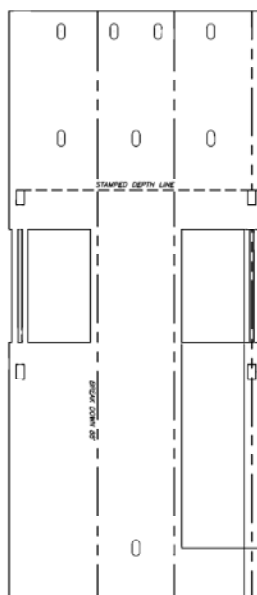

4" Post Mount

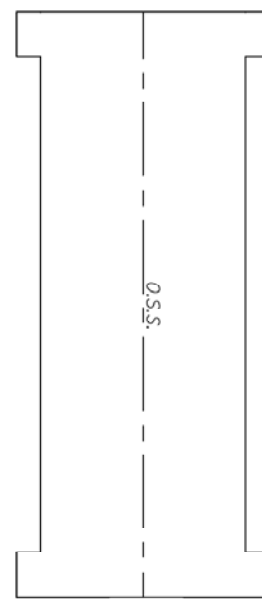

4" Post Mount Plate